

S-886M-xxS3
SSTL CRYOGENIC SWING CHECK VALVE
METAL SEAT W/ SOCKET WELD ENDS

CWP 720 PSIG NON-SHOCK COLD
TEMPERATURE RATING +150°F TO -325°F

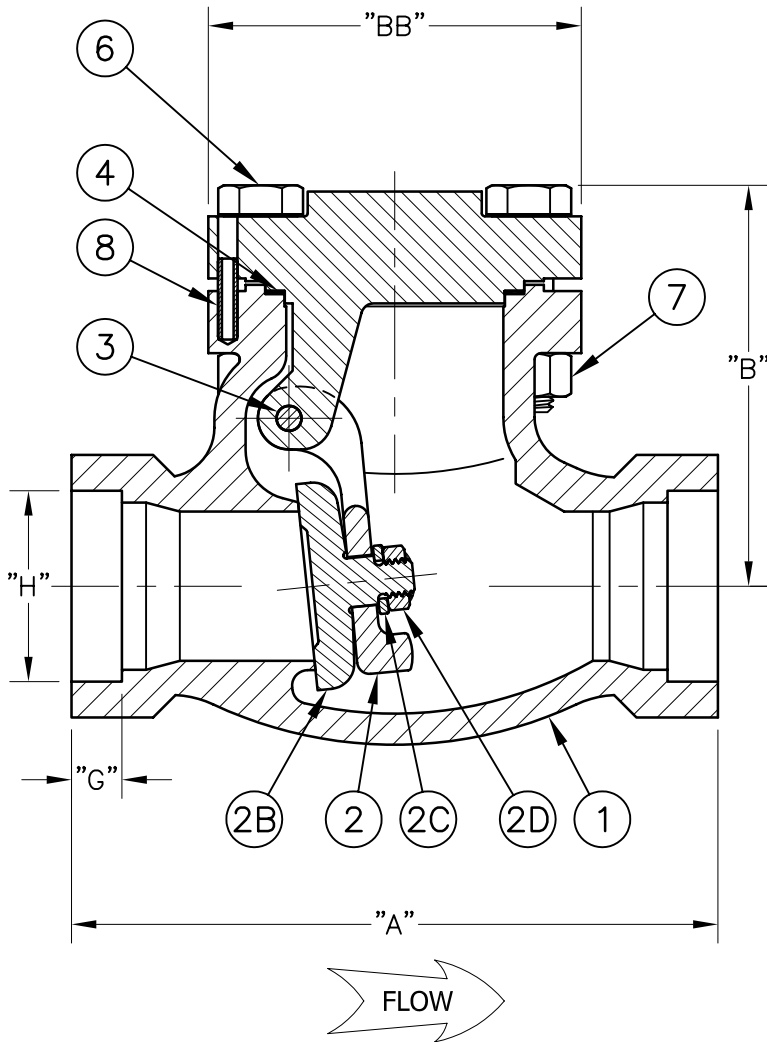

#	ITEM	MATERIAL SPEC.	KIT #
* 1	BODY	ASTM A351 CF8M ASME SA351 CF3M	
2	ARM	ASTM A351 CF3M	1
2B	SEAT	ASTM A276 S31600 ASTM A479 S31603	1
▲ 2C	WASHER	ASTM A479 S31603	1
2D	NUT	ASTM F594 S31600	1
3	PIN	NITRONIC 60 S21800	1
4	GASKET	25% GLASS FILLED TFE	1, 2
* 5	CAP	ASTM A351 CF3M	
6	BOLT	ASTM A320 S30400	
7	NUT	ASTM A194 S30400	
8	ROLL PIN	18-8 SSTL	

* INDICATES PART IS PRESSURE CONTAINING
▲ INDICATES PART IS ONLY USED ON "S-886M-12S3".

DIMENSIONS IN BRACKETS ARE IN MILLIMETERS

MODEL #	SIZE	"A"	"B"	"BB"	"H"	"G"
S-886M-4S3	1/2" [DN15]	4.25 [107.95]	2.44 [61.98]	2.38 [60.45]	.86 [21.84]	.38 [9.65]
S-886M-8S3	1" [DN25]	5.50 [139.70]	3.21 [81.53]	2.81 [73.47]	1.34 [34.04]	.50 [12.70]
S-886M-12S3	1 1/2" [DN40]	6.50 [165.10]	4.03 [102.36]	3.75 [95.25]	1.92 [48.77]	.51 [12.95]

MODEL #	#1 SEAT ASM KIT	#2 GASKET KIT
S-886M-4S3	S-886M-4-82	S-886-4-83
S-886M-8S3	S-886M-8-82	S-886M-8-83
S-886M-12S3	S-886M-12-82	S-886M-12-83